

SAINT JOSEPH'S PREPARATORY SCHOOL  
 PHYSICS TEST QUESTIONS..... T P FITZPATRICK  
 TORQUE

1. Find the tension in the supporting wire in each of the figures.

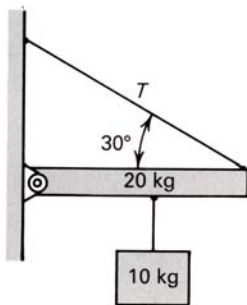

(a)

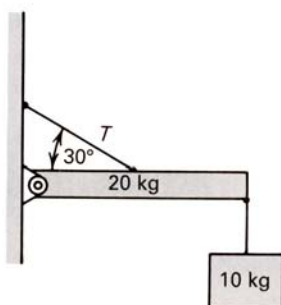

(b)

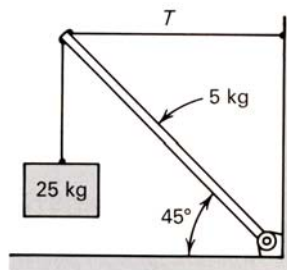

(c)

$T_a$ : \_\_\_\_\_

$T_b$ : \_\_\_\_\_

$T_c$ : \_\_\_\_\_

2. Find the tension in the supporting wire. The beam is uniform, the weight is suspended from the middle of the beam and the wire is attached to the end of the beam.

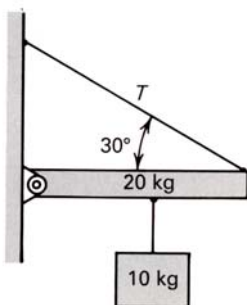

$T$ : \_\_\_\_\_

3. Find the tension in the supporting wire. The beam is uniform, the weight is suspended from the end of the beam and the supporting wire is attached at the middle of the beam.

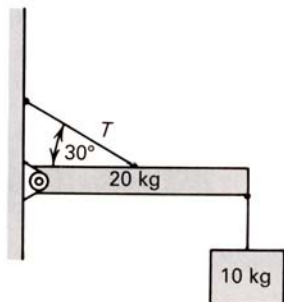

T: \_\_\_\_\_

4. Find the tension in the supporting wire. The beam is uniform and the support and weight are attached at the end of the beam.

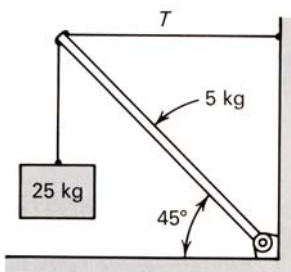

T: \_\_\_\_\_

5. Two masses,  $M_1 = 1.60$  kg and  $M_2 = 2.00$  kg are suspended from the ends of a light (essentially massless) aluminum rod of length 1.20 m as shown in the figure. The rod itself is suspended from the ceiling by a string. Find the tension in the string and the point on the rod where it must be attached so that the rod can remain horizontal.

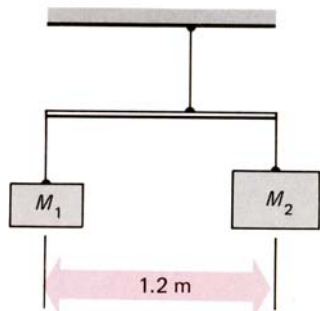

tension: \_\_\_\_\_

location: \_\_\_\_\_

SAINT JOSEPH'S PREPARATORY SCHOOL  
 PHYSICS TEST QUESTIONS..... T P FITZPATRICK  
**TORQUE**

6. a 1.20 m long uniform rod whose mass is 2.00 kg is supported from the ceiling by two light, thin cords as shown. Determine the tension in each cord and the mass M.

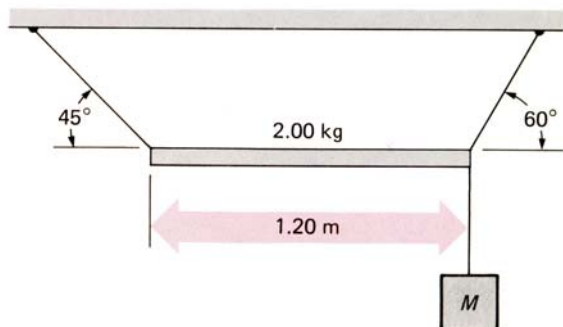

tension (left): \_\_\_\_\_

tension (right): \_\_\_\_\_

mass: \_\_\_\_\_

7. A uniform beam of 20.0 kg mass is hinged to a vertical wall and supported at its other end by a wire, as shown. What is the value of the mass supported by the beam if the tension in the wire is 500 N? What is the force exerted by the hinge on the beam?

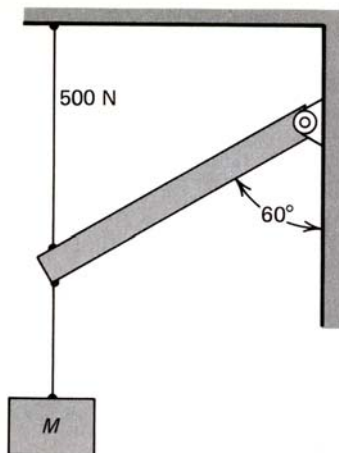

mass: \_\_\_\_\_

$F_x$ : \_\_\_\_\_

$F_y$ : \_\_\_\_\_

8. An 80.0 kg mast is maintained vertical by means of guy wires, as shown. The tension in the shorter guy wire is 800 N. find the tension in the other wire and the other forces acting on the mast from the boat. For simplicity, assume that no torque is exerted on the mast at its connection with the boat.

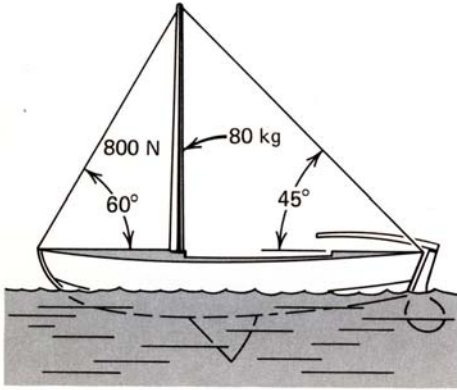

tension: \_\_\_\_\_

$F_x$ : \_\_\_\_\_

$F_y$ : \_\_\_\_\_

9. A uniform diving board whose mass is 60.0 kg is held fixed at two points, as shown. If an 80.0 kg diver stands at the edge of the board, what are the forces acting at the points of support?

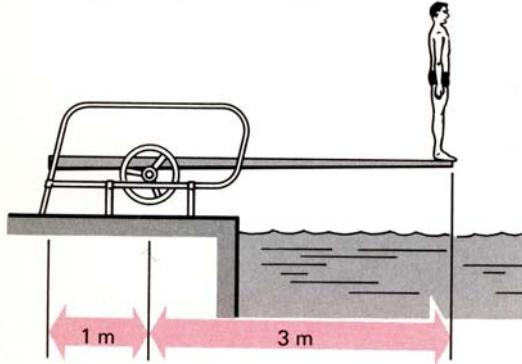

force (left): \_\_\_\_\_

force (right): \_\_\_\_\_

10. A sailor raises the jib using a halyard winch that he turns with a 25.0 cm long handle. The diameter of the winch is 8.00 cm. If he pulls on the winch handle with a force of 205 N as he tightens the jib, what is the tension in the jib halyard.

tension: \_\_\_\_\_

SAINT JOSEPH'S PREPARATORY SCHOOL  
 PHYSICS TEST QUESTIONS..... T P FITZPATRICK  
 TORQUE

11. A 0.20 kg meterstick is supported at its two ends, as shown. A mass of 0.80 kg is hung from the meterstick. Where should the mass be placed so that the force the meterstick exerts on the right-hand support is 3.00 N? (Be clear about how the location is measured.)

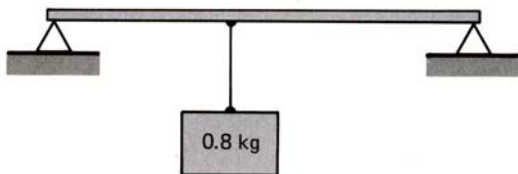

location: \_\_\_\_\_

12. A uniform block, 20.0 cm long and 50.0 cm high rests on an inclined plane. A small ridge prevents the block from slipping down the plane. What is the angle between the inclined plane and the horizontal at which the block topples over?

$\theta$ : \_\_\_\_\_

13. For the system shown, find the tension  $T$  and the force that the wall exerts on the beam.

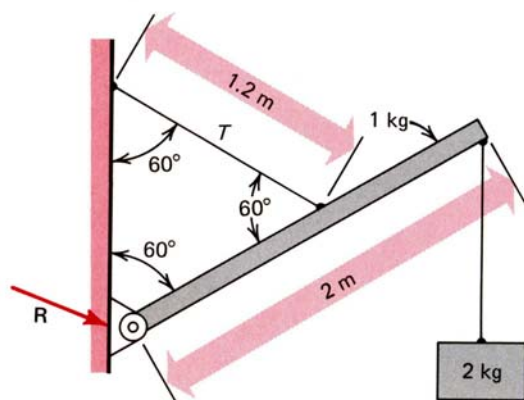

tension: \_\_\_\_\_  
 $F_x$ : \_\_\_\_\_  
 $F_y$ : \_\_\_\_\_

14. The figure shows a simple beam balance. The uniform balance arm is 20.0 cm long and 2.00 cm thick and has a mass of 150 g. It is supported by a thin wire attached to the top surface of the beam 12.0 cm from the left end. A mass of 10.0 g is suspended from the left end of the beam. What mass should be suspended from the right end of the beam to achieve equilibrium?

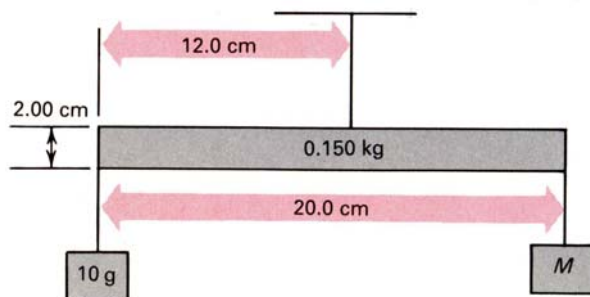

mass: \_\_\_\_\_

15. If a mass ( $M$ ) of 55.0 g is suspended from the right end of the uniform beam in the figure, what is the angle between the beam and the horizontal at equilibrium?

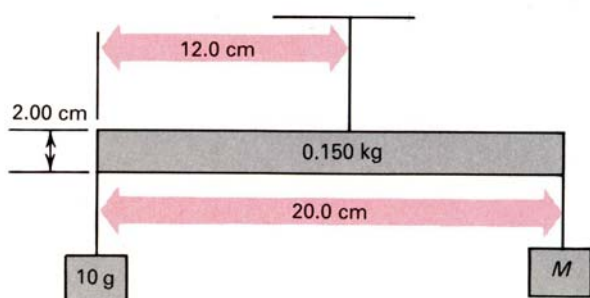

angle: \_\_\_\_\_

16. A beam of mass 15.0 kg is attached to the wall with a pin and supported by a string, as shown. The maximum tension that can be applied to the string is 500 N. If masses are suspended from the right end of the beam, what is the greatest total mass that can be hung from the beam without breaking the string?

mass: \_\_\_\_\_

SAINT JOSEPH'S PREPARATORY SCHOOL  
 PHYSICS TEST QUESTIONS..... T P FITZPATRICK  
 TORQUE

17. A volleyball net is strung between two poles that are supported by two guy wires each, as shown in the figure. What should the tension in each of the guy wires be so that the tension in the net is 150 N?

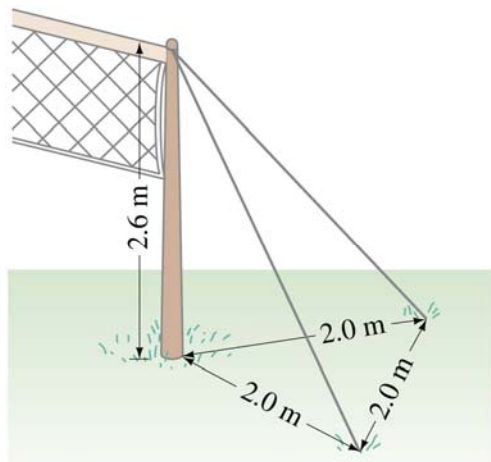

Copyright © 2005 Pearson Prentice Hall, Inc.

tension: \_\_\_\_\_

18. A uniform block, 20.0 cm long and 50.0 cm high, is placed on an inclined plane whose angle with the horizontal can be varied. Find the smallest value of the coefficient of static friction between block and plane such that, as the angle between plane and horizontal is increased, the block will topple over rather than slide down the plane.

$\mu_s$ : \_\_\_\_\_

19. A 10.0-kg uniform sphere rests in a smooth trough, as shown. Find the forces acting on the sphere.

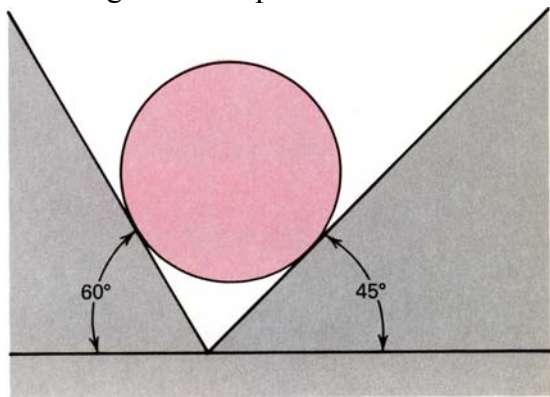

force (left): \_\_\_\_\_

force (right): \_\_\_\_\_

20. A 10.0 kg uniform ladder of length 8.00 m leans against a smooth wall, as shown. The coefficient of friction between ladder and ground is only 0.40, and the angle the ladder makes with the horizontal is  $60.0^\circ$ . A 35.0 kg child climbs this ladder. Can he climb safely to the top? If not, at what height should he stop to avoid serious injury?

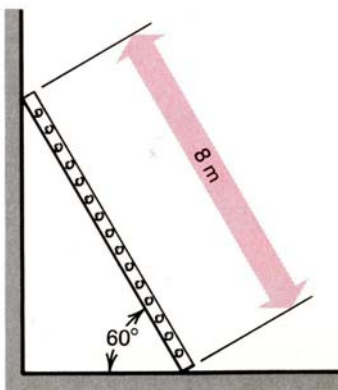

maximum height: \_\_\_\_\_

21. A 10.0 m long ladder has a mass of 20.0 kg. It leans against a smooth vertical wall, with its bottom resting on the ground 3.00 m from the wall. What must the minimum coefficient of static friction ( $\mu_s$ ) between ladder and ground be so that a 70.0-kg person can climb safely 80 percent of the way up the ladder?

$\mu_s$ : \_\_\_\_\_

22. A 10.0 m long ladder has a mass of 20.0 kg. It leans against a smooth vertical wall, with its bottom resting on the ground 3.00 m from the wall. If the coefficient of static friction ( $\mu_s$ ) between ladder and ground is 0.27, how far up the ladder can a 50.0 kg person climb safely? How far up the ladder could an 80.0 kg person climb safely?

50 kg: \_\_\_\_\_

80 kg: \_\_\_\_\_

SAINT JOSEPH'S PREPARATORY SCHOOL  
 PHYSICS TEST QUESTIONS..... T P FITZPATRICK  
 TORQUE

23. A mover has positioned his cart under a 75.0 kg uniform crate that is 30.0 cm long and 1.00 m high. He holds the cart in position by placing the toes of his shoes behind the wheels and then pulls back on the handles, which are 1.20 m aboveground. Find the force with which he must pull back to lift the front wheels of the cart off the ground (neglect the mass of the cart).

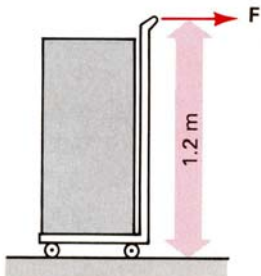

force: \_\_\_\_\_

24. Find the tension in the rope supporting the uniform crate. The crate contacts the horizontal surface only at point A.

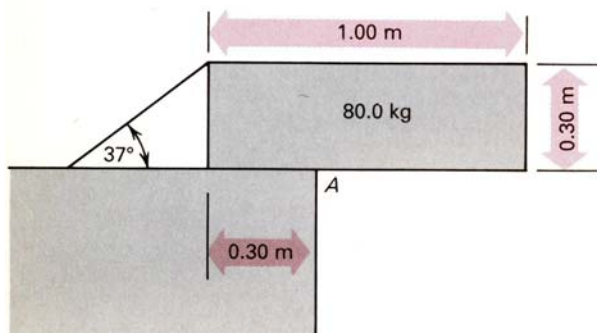

tension: \_\_\_\_\_

25. A non-uniform meter stick with a mass of 120 g is supported at the 70.0 cm mark and is balanced when a total of 75.0 g is suspended from the 90.0 cm mark. Where is the center of mass of the meter stick?

location: \_\_\_\_\_